

Planned Islanding on Rural Feeders - Utility Perspective

Farid Katiraei ^{1*}, *Member, IEEE*, Chad Abbey ¹, *Student Member, IEEE*
Susan Tang ², Maude Gauthier ³

- 1) CANMET Energy Technology Centre - Varennes, Natural Resources Canada,
- 2) Distribution Planning - BC Hydro, Burnaby - Canada,
- 3) Asset Management - Hydro Quebec Distribution, Montreal - Canada

Abstract—Planned islanding application, also known as intentional islanding, is an early utility adaptation of the Microgrid concept that is being promoted by major utilities around the world. The main objective of planned islanding projects in Canada is to enhance customer-based power supply reliability on rural feeders by utilizing an appropriately located independent power producer (IPP). This paper considers the process of planned islanding and the necessary steps that need to be taken in order to lead to successful projects. Some of the current experience from Canadian utilities in this area are investigated and the additional requirements, in terms of equipment and system studies, which are needed in order to plan for the operation of a planned island project are discussed. A case of planned islanding on rural feeders with multiple distributed generation units is also investigated, which represents the target of future projects in this area.

Index Terms—Distributed Generation, planned islanding, intentional islanding, interconnection standards, reliability, rural feeders.

I. INTRODUCTION

Planned islanding and autonomous operation of part of a distribution network supplied by local distributed generation (DG) units has recently attracted major utilities interest worldwide, [1], [2]. The concept can potentially improve reliability and supply security on rural feeders by reducing system downtime. It also allows the utility company to perform maintenance on upstream medium/high voltage systems without supply interruption of the low voltage customers.

Planned islanding may be used during planned outages, for instance for maintenance purposes on distribution substations or high-voltage (HV) lines. In this case, a common practice is to dispatch a controllable DG to balance the power generation and consumption locally prior to disconnection from the utility grid. However, in response to unanticipated switching events on upstream lines (e.g. faults on HV lines and forced power outages), a planned islanding may happen by attempting to ride through the islanding transients. If the local generation plants can successfully pick up the load and stabilize the voltage and frequency of the island (within appropriate ranges) without load interruption, then the planned islanding is sustained. If the islanding fails due to large transients and

consequential protection actions, black-start procedures can be used to pick up the load in pre-specified portions.

To perform a planned islanding project the power plant has to have adequate reserve capacity and be equipped with proper voltage/frequency control apparatus in order to: respond to load demand, meet voltage and frequency requirements and sustain an island. Those requirements are certainly atypical for private power producers considering current utility practices normally require that DGs disconnect when the substation supply is lost or a feeder reclosure is opened, [3]. Consequently, both the DG plant and the connecting substation should be modified to accommodate planned islanding of the local network and supply of a community load at an adequate power quality level. The process also involves various detailed technical studies to ensure appropriate protection and control systems are in place to serve the islanded system in the same manner as an interconnected system. Concurrently, standards coordinating committees are developing new guidelines and recommendations to facilitate intentional islanding practices, [4].

The first part of this paper explores utility approaches towards planned islanding design and operation considering existing projects in Canada. The reported cases are all based on a single generation source or utilizing a centralized power plant to supply the island load. However, as DG units are being integrated to distribution systems in larger scales, two or more generation sources may become available in the vicinity of a clustered load. Presence of multiple sources potentially increases the load serving capability and feasibility of a large-area island. The second part of the paper discusses some of the challenges for implementing a multiple DG planned island as a future trend towards development of Microgrids. Simulation studies are performed on a two-DG planned islanding case to investigate dynamic behavior of the study system for two proposed control strategies.

II. CUSTOMER-BASED RELIABILITY ENHANCEMENT ON RURAL FEEDERS

The planned islanding application is investigated on some rural feeders in Canada to improve the reliability of supply for rural communities, where the corresponding distribution substation (or transformer station) is only supplied by a single HV line [5]. Customers on those feeders may experience sustained

* Corresponding author: Farid Katiraei, Natural Resources Canada, CANMET Energy Technology Centre-Varennes, 1615 Lionet-Boulet Blvd., Quebec, Canada, J3X 1S6, (email: farid.katiraei@nrca.gc.ca)

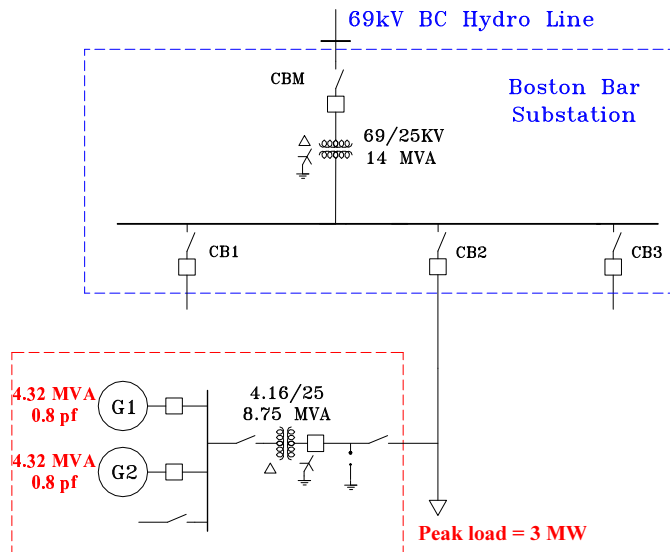

Fig. 1. BC Hydro Boston Bar system configuration for planned islanding

power outages for several hours a few times per year due to environmental and weather impacts that resulted in permanent faults on the HV feeder. However, a local independent power producer (IPP) equipped with additional equipment can be employed to supply the load downstream of the substation when the HV line is down or during maintenance of the substation. As an incentive and to justify additional equipment costs the IPP will be paid bonus based on the amount of load served during a power outage, if it can successfully sustain the island.

Reliability improvement is the motivation for planned islanding case studies in Canada. BC Hydro has been one of the leaders in this area having successfully operated a planned islanding project for over a decade [2], and recently commissioned a second site, while undergoing design and testing of a third planned islanding project. BC Hydro has also developed a planned islanding guideline to help IPPs evaluate and prepare project applications, [6]. Planned islanding has been also performed at Hydro-Quebec (HQ) for maintenance of old HV lines supplying a rural distribution system, [7]. Two project examples are discussed in the following subsections.

A. BC Hydro - Boston Bar Planned Islanding

Fig. 1 shows the one-line diagram of the BC Hydro Boston Bar 69/25 kV substation comprising of three radial feeders and an 8.6-MVA run-of-river hydro-electric plant [2]. The hydro-electric plant is operated by an IPP and connected to one of the feeders with a winter peak load of 3-MW.

Power outages between 12- and 20-hour periods a couple of times per year are typically experienced due to permanent outages on the 69-kV line connecting the substation to the BC Hydro grid. The hydro-power plant is equipped with islanding capability. Depending on the water level, the Boston Bar IPP can supply the community load on one or more of the feeders during the islanding operation. If the water level is not sufficient, the load on one feeder can be sectionized to adequate portions. Based on the BC Hydro islanding guideline,

to perform planned islanding, an IPP should be equipped with additional equipment and control systems for voltage regulation, frequency stabilization, and fault protection. In addition, the island-load serving capability of an IPP needs to be tested prior to and during the project commissioning to ensure that the IPP can properly respond to load transients such as a step change in load.

The functional requirements added to the Boston Bar IPP to support planned islanding are as follows:

- 1) Governor speed control with fixed-frequency (isochronous) mode for single unit operation and speed-droop settings for two-unit operation in parallel,
- 2) Engineering mass of generators and hydro turbines to increase inertia and improve transient response,
- 3) Excitation system control with positive voltage field forcing for output current boost during the feeder fault to supply high fault current for proper coordination of protection relays,
- 4) Automatic voltage regulation (AVR) control to regulate voltages at the PCC,
- 5) Two sets of over current protection set-points for the grid-connected and the islanding operating modes,
- 6) Real-time data telemetry via leased telephone line between the IPP remote control site and the utility Area Control Centre,
- 7) Black start capability via an on-site 55-kW diesel generator.

In addition to the above upgrades, remote auto-synchronization capability was also added at the substation level to synchronize and re-connect the island area to the 69-kV feeder without causing load interruption.

When a sustained power outage event, such as a permanent fault or line break-down, occurs on the utility side of the substation, the main circuit breaker (CBM) and feeder reclosers (CB1 to CB3) are opened, Fig. 1. Then, the substation breaker open position is telemetered to the IPP operator. Subsequently, the IPP changes the control and protection settings to the island mode and attempts to hold the island downstream of CB2. If the IPP fails to sustain the island, the IPP activate a black-start procedure and picks up the dead feeder load under the utility supervision. The island load may be supplied by one generator or both generators in parallel.

Two sets of tests were performed during the generator commissioning as follows:

- 1) Grid parallel operation tests including (a) the automatic and manual synchronization, and (b) output load, voltage and frequency controls and load rejection tests,
- 2) Island operation tests comprising of (a) load pick-up and drop-off tests in 350-kW increments, (b) dead load pick-up of 1.2-MW when only one of the two generators is in operation, and (c) islanded operation and load following capability when one unit is generating and/or both units are operating in parallel.

The planned islanding practice has been functioning since 1995 and has resulted in significant reliability improvements for this BC Hydro system and financial gains for the local IPP. The project provides excellent experience basis for utilities.

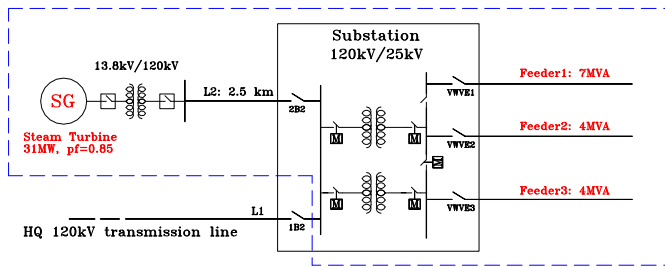

Fig. 2. HQ Senneterre substation configuration with supply lines from the HQ transmission system and the Boralex power plant (planned islanding area is shown within dash line)

B. Hydro Quebec Planned Islanding

HQ's most recent planned islanding experience began when considering options for the maintenance of the transmission line feeding a substation named Senneterre, where a privately-owned thermal power plant (Boralex) was interconnected, [7]. The one-line diagram of the substation is shown in Fig. 2. The substation feeds three distribution lines, serving 3000 customers in the municipality of Senneterre and its surrounding area. This substation is supplied at 120 kV by a 40 km long transmission line. Standing on wooden structures, this line, more than 55 years old, required urgent replacement of its angle and stop portals. This type of maintenance can only be performed on a de-energized line. Presently, HQ has no backup feed, neither from Transmission nor Distribution. However, the Boralex thermal power plant, which has been feeding the HQ network since 2002, is connected through the Senneterre substation. To avoid service interruption for HQ customers during the restoration of the transmission line, it was decided to consider the option of using the Boralex power plant for islanding of HQ's Senneterre substation.

Several studies performed to investigate the planned islanding operation of the substation and corresponding feeders supplied by the thermal plant. The main studies include: (1) Protection studies to verify protection coordination at a new minimum short-circuit level (reduced value), (2) Stability study of the island area and the power plant for cold load pick-up, start-up of motor loads, and in response to high current faults, and (3) Flicker study based on evaluation of flicker level from various sources.

In October 2005, the first attempt of islanding of the HQ Senneterre system by the Boralex power plant was performed and persisted for eight hours. A planned outage strategy based on matching load/generation prior to disconnection was applied. The peak load during the event was measured near 7 MW. During this experience, the stability of the system was validated for significant variations in load including: (a) the disconnection and reconnection of one distribution feeder at a time, and (b) the disconnection of all three distribution feeders by which the only loading on the power plant was the substation and power plant auxiliary loads. Results showed that voltage and frequency remained stable for both the load reduction test and the controlled load augmentation process.

III. PLANNED ISLANDING WITH MULTIPLE DG UNITS

Rural feeders are normally long and serve a large area with significant differences between minimum and maximum load. Hence, a single DG would not normally be enough to supply an entire load of a feeder or entire area downstream of a distribution substation and/or a transformer station (D/TS). In addition, renewable energy based DG units (e.g. hydro, wind, and/or solar PV generation) are variable in nature. The resource intermittency reduces the firm and load-carrying capacities of DG plants. Diversifying the generation and utilizing multiple DG units connected to the same feeder or on adjacent feeders of a D/TS can potentially increase the reserve power and expand the island area to supply additional customers. However, planned islanding of multiple DG units involves various design challenges and may require complex control and operation strategies to the extent that no utility case has been reported.

A multiple DG planned islanding case is conceptually similar to implementation of "remote power systems" for isolated areas and geographical islands with several generation sources. However, typical remote power system designs tend to favor a centralized power plant architecture with oversized and redundant generation units. In most cases, some sort of "energy storage" is used to perform voltage and frequency regulation and maintain sufficient generation reserve, [8], [9]. These approaches are very costly and may not be applicable for outage management on rural feeders for two reasons: (1) the system operates in connection to the main grid most of the time and may become an island only a few times per year, (2) multiple DG units may be some distance apart which requires distributed control and advanced power management strategies.

This part of the paper investigates alternative design and control options for coordinated operation of a two-DG planned islanding case. The primary focus is on technical consideration, although some regulatory and/or non-technical complications related to "ancillary service" utilization mechanisms may be encountered, [10].

A. Study system

Figure 3 shows a benchmark used as the basis for the modelling and studies of this section. The benchmark system is an extended version of the BC Hydro planned islanding case of Fig. 1 by addition of a 4.4-MW run-of-river hydro power plant on Feeder 3. Maximum load of each feeder is 3.0-MW. It is not difficult to find similar cases in BC Hydro distribution systems with two or three hydro plants connecting on the same or adjacent feeder(s) and serving rural community loads. The proposed studies are typical test cases that are normally used by utility engineers to determine voltage/frequency stability and load serving capability of an isolated power system.

B. DG Controls

Typical hydro power generator controls consist of a governor system for speed control and automatic voltage regulator (AVR) through its excitation system for terminal voltage

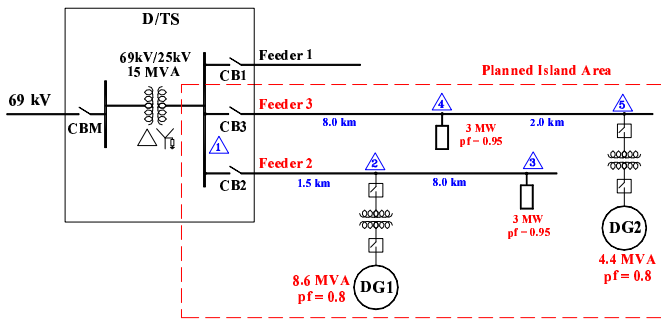

Fig. 3. Two DG benchmark for planned islanding studies

adjustment. During a grid-connected mode, DG units may not participate in the voltage/frequency regulation and normally operate in a “constant power mode” supplying active and reactive power at pre-specified levels. Active power control is performed through adjusting the governor speed reference and reactive power is set through AVR reference.

When DG control is switched to an islanding mode, the external power control loops are disabled and replaced by new control blocks depending on the islanding control strategy. Alternatively, fixed voltage and frequency references can be chosen and applied to the governor/AVR system as new set points.

Formation of an island and change in the operating mode of DG units are determined through monitoring and communicating open/close contact positions of D/TS circuit breakers (CBs) in order to quickly respond to forced power outages. Radio frequency based communication scheme (telemetry) and/or communication through leased telephone lines can be used as practical options in rural areas to send islanding signals to DG units. These communication methods are conceptually similar to the transfer-trip schemes that are normally required by utilities at present; therefore, they may not cause additional complexity to the design.

Two control strategies are proposed and modelled for islanding operation:

- 1) **A master-slave method:** Based on this strategy, subsequent to islanding, control modes of one of the DG units (e.g. DG1) are changed to voltage regulation and fixed-frequency (isochronous) control, hence the generator acts as a swing source. However, DG2’s controls remain the same as those of the grid-connected operation (i.e. constant power control). Power set-point of DG2 is determined through a secondary dispatch control scheme of DG1 and sent through a slow communication channel connecting the two DG units.
- 2) **Active load sharing method (droop control):** This control strategy enforces all DG units of an island to respond to islanding transients and contribute to serving the load. Upon disconnection from the main grid and detection of an islanding situation, control methods of the DG units are changed to island control modes based on voltage following and frequency adjustment using voltage/frequency droop characteristics. The frequency droop scheme increases the active power of a DG unit

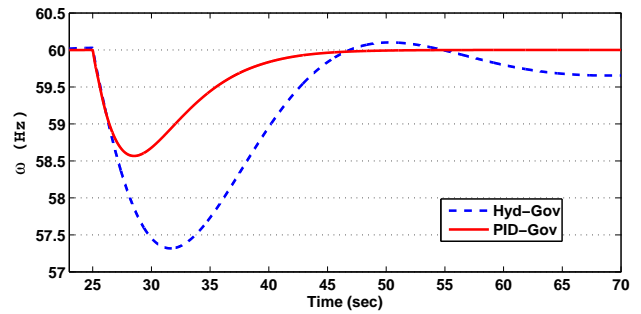

Fig. 4. Case A - Load pick-up test on DG1 for two types of governors: Hyd-Gov and PID-Gov

as the frequency decreases (or viceversa) based on a pre-determined rate. Similarly, the voltage droop acts upon variations in the DG terminal voltage to control its reactive power output.

C. Case studies

Several studies are performed to demonstrate dynamic behavior and range of variations in voltage and frequency of the islanded system following a planned islanding transition. Case A a primary test normally performed to determine dynamic characteristics of typical governor systems to select proper speed controls. Cases B to D model planned islanding of single and two-DG systems.

1) **Case A - Load acceptance:** As discussed in Section II-A, turbine-generator mass and governor system performance have significant impact on frequency control and load following capability of generation sources of an island. Normally, off-line load pick-up and drop-off tests are performed to determine generator speed/frequency control characteristics. Figure 4 shows speed variations of DG1 in response to a load pick-up test for two types of governor systems: (1) a generic hydraulic governor (Hyd-Gov) with proportional control and a transient droop compensation loop, and (2) a fast acting electronic governor comprising of “Proportional + Integral + Derivative (PID)” control (PID-Gov). Detailed governor models are explained in [11]. In Fig. 4, a step load addition of 1.0-MW at $t=25$ s, under similar pre-loading conditions, causes a frequency deviation of about -1.5 Hz when the hydro generator is equipped with “PID-Gov” and a frequency excursion of -2.7 Hz for “Hyd-Gov”. The PID governor also demonstrates a faster frequency recovery time and enhanced transients which are essential for islanding and isolated operation. In the following studies, the PID type governor is used for both DG1 and DG2.

2) **Case B - Single DG planned islanding:** Utility experience with single DG planned islanding cases have been described earlier. Here, the BC Hydro case of Section II-A is modelled to provide a base-case scenario for analyzing simulation results of two-DG cases. Figure 5 shows planned islanding of Feeder 2 at $t=25$ s for the benchmark system of Fig. 3.

Prior to the islanding, the difference between load and generation (power mismatch) is set to 1.2-MW under generation (40% mismatch) for 3.0-MW/0.99-MVAr maximum

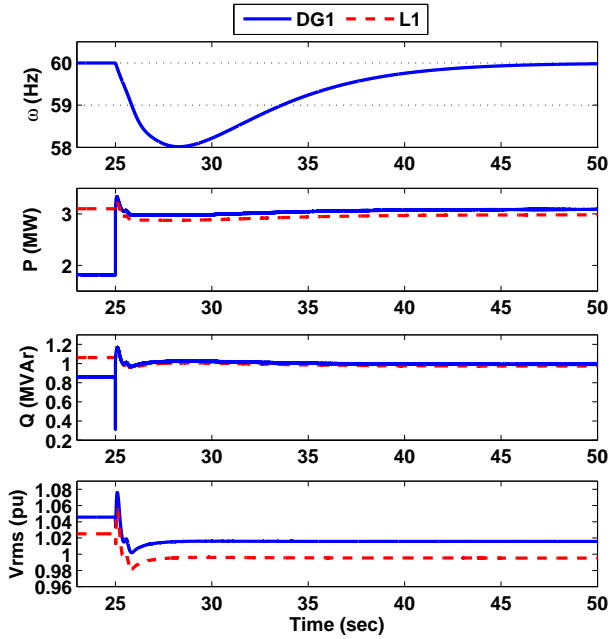

Fig. 5. Case B - Planned islanding of Feeder2 at 40% power mismatch (DG1+L1)

feeder load. The planned islanding situation is determined by communicating the CB2 open-contact position to DG1 site. A maximum data communication delay time of 0.5 s is applied. By detecting the opening of CB2, the DG1 control strategy is changed to voltage and frequency regulation. Figure 5-b shows that output power of DG1 increases to match the load. Due to a large power mismatch, the system frequency, which is measured based on changes in the generator rotational speed, first decreases to about 58 Hz and then gradually recovers to 60 Hz, Fig. 5-a. The load voltage also deviates from its nominal value; however, it is quickly regulated by DG1 and kept within an acceptable range, Fig. 5-d.

The simulation results of Fig. 5 show that DG1 equipped with proper controls can ride through transients and sustain islanding of Feeder 2 under a large power mismatch, provided that the generation unit has adequate reserve capacity to supply the maximum load. As illustrated in Fig. 4, DG1 also has proper load following capability for any change in load below 1.0-MW during the islanded operation. The voltage and frequency excursions are also maintained in a reasonable range typical of isolated power systems ($\Delta f = \pm 1.5$ Hz and $\Delta V = \pm 10\%$).

3) **Case C - Two-DG planned islanding, Master-slave control:** Planned islanding of Feeders 2 and 3 with corresponding cluster loads (L1 and L2) and DG units (DG1 and DG2), Fig. 3, is investigated in this study. An island area is formed by simultaneous opening of CBM and CB1 to isolate the study feeders.

Figure 6 shows dynamic behavior of the two-DG planned islanding following disconnection from D/TS when a master (DG1) - slave (DG2) control strategy is applied to the DG units, Section III-B. During the grid-connected mode, the operating points of DG1 and DG2 are set to 2.73-MW/0.86-MVAR

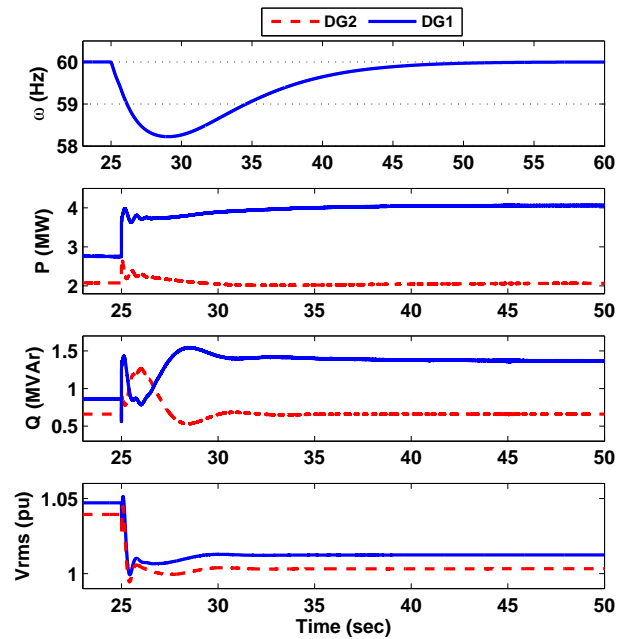

Fig. 6. Case C - Two DG island with master-slave control

and 2.068-MW/0.66-MVAR, respectively. This operating point represents a power mismatch of 1.2-MW based on overall two-feeder load of 6.0-MW/1.98-MVAR. Islanding occurs at $t=25$ s.

Figures 6-b and 6-c show that DG1 dominantly responds to the islanding transients and compensates the difference between load and generation while regulating voltage and stabilizing the power frequency. Although the DG2 output powers are momentarily changed after islanding, the steady-state values are the same as the pre-islanding conditions. The maximum frequency excursion is about 2 Hz, Fig. 6-a, which is similar to that of Case B, Fig. 5-a.

4) Case D - Two-DG planned islanding, Load sharing:

This case investigates a two-DG planned islanding scenario based on active load sharing among the generation units, Section III-B. The islanded area is the same as Case C and a pre-islanding power mismatch of 1.2-MW is considered as well. Prior to the islanding, DG1 and DG2 supply 3.17-MW/1.03-MVAR and 1.62-MW/0.53-MVAR, respectively.

Figures 7-b and 7-c show that both DG units simultaneously respond to the islanding transients and aim to sustain the island. Consequently, the island load is divided between two DG units proportional to their rated capacities. In comparison to simulation results of Case C, deviations in the power frequency, Fig. 7-a, is lower than those of Fig. 6-a. This is mainly due to the fact that both DG units contribute to supplying the load.

Based on load sharing strategy, local variations in a DG terminal voltage and power frequency determine changes in the active and reactive power of the DG unit. When multi-DG units are involved, a combination of load sharing and master-slave dispatch strategy can be used to provide effective generation control and capacity sharing among all units.

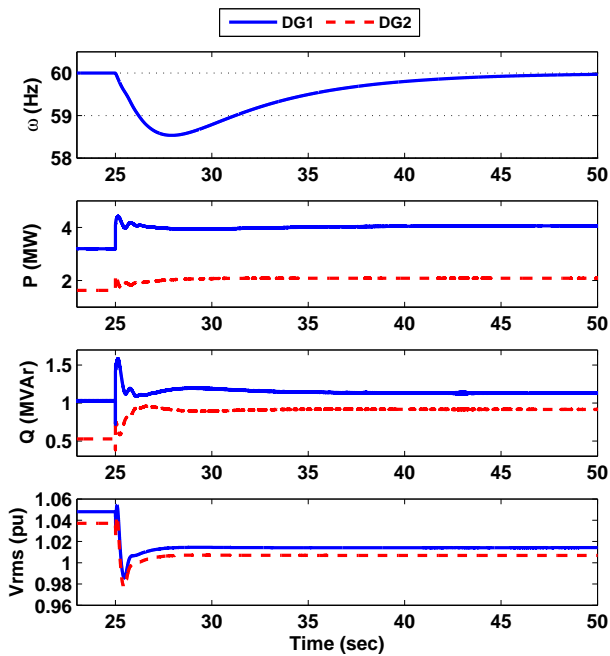

Fig. 7. Case D - Two DG island with droop control

D. Protection consideration

Perhaps, the key challenge for performing planned islanding of multiple DG units and, in general, toward implementation of Microgrids is design of a protection system architecture that provides adequate level of fault protection during a grid-connected mode as well as an islanding mode. The short-circuit level of a system may be significantly different in the two modes, even though synchronous generator based DG units are used. Table I shows changes in short-circuit currents for three phases to ground faults (3L-G) at various nodes of the benchmark system for two cases of (1) connection to the D/TS and (2) two-feeder islanding.

Changes in the minimum short-circuit currents along with possible variations in protection zones may affect the CB-CB coordination of the feeders and/or CB-fuses coordination of laterals. Although no general solution currently exists to properly address this challenge, revisiting the protection coordinations to specify new protection settings for an island mode, and utilizing fault current boosting methods, for instance, through positive generator voltage feedback for field forcing are recommended.

IV. CONCLUSIONS

This paper outlined several cases of existing planned islanding and potential future projects. Investigation of the project approaches and operation strategies during planned islanding operation periods revealed that planned islanding is a feasible option that can be used in many applications to improve reliability of customers on rural feeders during sustained power outages or planned interruptions. Similarly the concept can be applied to feeders supplied by two or more DGs. Several operating modes were introduced and

TABLE I

CHANGES IN SHORT-CIRCUIT CURRENTS (IN AMPERE) FOR 3L-G FAULT

| Isc(A) Node: | 1 | 2 | 3 | 4 | 5 |
|-----------------------|------|------|------|------|------|
| <i>Grid connected</i> | 3749 | 3338 | 1712 | 2079 | 1884 |
| <i>Islanded</i> | 854 | 866 | 695 | 807 | 799 |

planned islanding scenarios were modelled on a test system. The simulation results showed enhanced islanding capability and a wider range of customer load serving when two DGs are used.

REFERENCES

- [1] H. You *et al.*, "Self-healing in power systems: an approach using islanding and rate of frequency decline-based load shedding," *IEEE Trans. Power Syst.*, vol. 18, no. 1, pp. 174–181, Feb. 2002.
- [2] R. Fulton and C. Abbey, "Planned islanding of 8.6 MVA IPP for BC Hydro system reliability," in *First International Conference on the integration of RE and DER*, Dec. 2004, pp. 1–9.
- [3] *IEEE Standard for Interconnecting Distributed Resources with Electric Power Systems*, IEEE Standards Coordinating Committee 21 Std. IEEE Std. 1547-2003, 2003.
- [4] *IEEE Draft Guide for Design, Operation, and Integration of Distributed Resource Island Systems with Electric Power Systems*, IEEE Standards Coordinating Committee 21 Std. IEEE P1547.4.
- [5] C. Abbey *et al.*, "Overview of wind and distributed generation applications in Canada," in *Proc. IEEE PES General Meeting 2006*, Montreal, Canada, June 2006.
- [6] (2006) BC Hydro - Distribution Power Generator Islanding Guidelines. [Online]. Available: <http://www.bchydro.com/info/ipp/ipp992.html>
- [7] M. Gauthier *et al.*, "Planned islanding as a distribution system operation tool for reliability enhancement," in *Proc. 19th International Conference on electricity distribution CIREN 2007*, Vienna, Austria, May 2007.
- [8] B. Wichert, "PV-Diesel hybrid energy systems for remote area power generation - a review of current practice and future developments," *Renewable and Sustainable Energy Reviews*, vol. 1, no. 3, pp. 209–228, 1997.
- [9] N. Lipman, "Overview of wind/diesel systems," *Renewable Energy*, vol. 5, no. Part I, pp. 595–617, 1990.
- [10] G. Joos *et al.*, "The potential of distributed generation to provide ancillary services," in *Proc. IEEE PES General Summer Meeting 2000*, vol. 3, 2000, pp. 1762–1767.
- [11] C. Mello *et al.*, "Hydraulic turbine and turbine control models for system dynamic studies [J]," *IEEE Transactions on Power Systems*, vol. 7, no. 1, pp. 167–179, 1992.

F. Khatraei (S'01, M'05) received the B.Sc. and M.Sc. degrees in electrical engineering from Isfahan University of Technology (Iran) in 1995 and 1998 respectively. He received his Ph.D. degree also in electrical engineering from the University of Toronto (Toronto-Canada) in 2005. He is currently a T&D research engineer at CANMET Energy Technology Center (CETC-Varenes). His research includes power electronic applications in power systems, distributed energy generation systems, and microgrids.

C. Abbey (S'01) received his degree in electrical engineering from the University of Alberta in 2002. In 2004, he graduated with an M. Eng degree from McGill University, Montreal where he is currently pursuing his Ph.D.

He is presently working with CANMET Energy Technology Centre, in Varennes, where he is a Research Engineer and coordinates a joint research program on the modeling and integration of distributed generation. His current research interests include wind energy, distributed generation, and their integration to the grid.

S. (Xiaosu) Tang received the B.Eng. and M.Sc. degrees in electrical engineering from Chongqing University (P.R. China) in 1997 and from University of Saskatchewan (Canada) in 2000 respectively. She is currently the distributed generation planning leader in BC Hydro distribution planning, taking the technical lead in interconnecting generators to BC Hydro distribution system.

M. Gauthier received her B.Sc. degree in power electrical engineering from cole Polytechnique de Montreal in 2004. She is currently working as an electrical engineer for Hydro-Quebec, in Montreal, where she is actively participating to distributed generation integration requirements development.